

JOURNAL OF ENGINEERING, EMERGING TECHNOLOGIES AND APPLIED SCIENCES (JEETAS)

A PUBLICATION OF THE FACULTY OF ENGINEERING, NIGER DELTA UNIVERSITY

APRIL 2023

VOLUME 01

ISSUE 01

ARTICLES

- ✓ A message From the Editor-in-Chief
Z. R. Yelebe 1
- ✓ Evaluation of an Alternative Source of Power for Ship Operations in Ports
G. O. Nwaorgu and E. A. Ogbonnaya 2 - 12
- ✓ Design and Implementation of an Online Coronavirus Testing Software
O. O. Shoewu, L. A. Akinyemi, Q. A. Mumuni, A. A. Ajasa, C. O. Folorunso and M. O. Rafiu 13 - 24
- ✓ Reinforcement of Cast Iron with the Ashes of Animal Bone for the Production of Engineering Components
T. J. Ajoko and E. Amula 25 - 32
- ✓ Synthesis and characterization of Zinc oxide nanoparticles-polyvinyl alcohol-polyethylene glycol nanofluids (ZNO-Nps-PVA-PEG-NF)
O. Ketebu 33 - 39
- ✓ Production of Perfume and Determination of the Physiochemical Features from Locally Available Lemongrass Leaves Extract
A. Sakwe and E. P. Uku 40 - 46
- ✓ Effects of Non-Standard Refined Diesel Fuel Oil on the Combustion Characteristics of a Diesel Engine and on the Environment
O. L. Bebetidoh, K. Pazouki, and R. Norman 47 - 61
- ✓ An Improved Wearable Medication Reminder System Using Peripheral Interface Controller for Persons with Arrhythmia
S. Adeniyi, K. E. Jack, A. O. Bankole, A. A. Oguntuyi, A. A. Ginyan, and O. M. Yusuf 62 - 74
- ✓ Development of a Robot Arm Using Electromagnet as End Effector To Carry Out Pick and Drop Operation
F. O. Agonga, J. C. Anunuso, and A. E. Jatau 75 - 81
- ✓ A Review on the Effect of Reaction Parameters on Biodiesel Production
B. J. Jonathan and B. E. Yabefa 82 - 84

**NIGER DELTA
UNIVERSITY**



Development of a Robot Arm Using Electromagnet as End Effector To Carry Out Pick and Drop Operation

Fred Oyinbonogha Agonga *, Justice Chikezie Anunuso**, Ayuba Elkanah Jatau***

*(Department of Mechanical Engineering, Niger Delta university, Amassoma

Email: agongofred@ndu.edu.ng)

** (Department of Mechatronics Engineering, Federal University of Technology Minna, Niger State

Email : j.aunuso@futminna.edu.ng)

***(Department of Mechanical Engineering Technology, Niger State Polytechnic Zungeru

Email : elkanahayubaj@gmail.com)

Abstract:

Owing to labour issues in industry, such as pick and drop operation of hazardous and heavy materials, there is a need to procure an autonomous solution. This article shows the creation and use of a model robotic arm that uses a magnetic gripper to load and unload light metal sheets. Two servo motors operate as actuators to control the arm's movement and the wrist's alignment. An Arduino microprocessor controls the arm, while a DC power source powers the electromagnet. To depict how the actual system will seem, the design was created using CAD software. This was subsequently physically applied to a functional system. The physical system is created through the combination of several components, and the electrical control system utilized an Arduino Uno microcontroller, for which a program was generated using the Arduino IDE to direct the movement of the servo motors and regulate the electromagnet. According to the results of the experiments, the robotic arm equipped with a magnetic end effector is capable of picking and dropping objects with a high degree of accuracy and effectiveness. The creation of a robot manipulator using an electromagnet as the end effector for pick and drop operations is discussed in this study, offering a practical solution for sectors that need to do repetitive tasks.

Keywords — Actuators, Electromagnet end effector , Industrial Automation, Microcontrolle , Magnetic Gripper, Robotic Arm, Simulation.

I. INTRODUCTION

A robot is an electromechanical device connected with joints and links, driven by motors or actuators guided by sensors and controlled through a software program to perform many different kinds of work (Moe Myint et al., 2016). The term 'robotics' was coined by a well-known Russian Science fiction writer Isaac Asimov sequel to this period, Karl Capek had written a play titled Rossum's Universal Robots which gave popularity to the term robotics in the 1920s (Ropo et al., 2018).

A robotic arm with an electromagnet as its end effector is a machine designed to pick up and drop objects using an electromagnet. This type of arm is commonly used in manufacturing and industrial settings where objects need to be moved and manipulated with precision and efficiency.

The electromagnet at the end of the arm can be turned on and off using an electric current, allowing it to attract and hold onto objects made of magnetic materials. The arm itself is typically made up of several joints that can be moved and rotated to position the end effector in the desired location (Islam & Islam 2014)

settings where objects need to be moved and manipulated with precision and efficiency.

The electromagnet at the end of the arm can be turned on and off using an electric current, allowing it to attract and hold onto objects made of magnetic materials. The arm itself is typically made up of several joints that can be moved and rotated to position the end effector in the desired location. (Islam & Islam, 2014).

The design of a robotic arm with an electromagnet as its end effector requires careful consideration of factors such as the weight of the objects to be moved, the precision required for positioning, and the range of motion needed for the arm. Additionally, the power source for the electromagnet and the control systems for the arm must also be carefully designed and integrated (Islam & Islam, 2014).

Over the years, robotics has found applications in several fields ranging from space exploration to medical fields, homes applications, laboratory research, manufacturing, and industries. Robots are generally used to perform highly repetitive and unpleasant tasks that seem strenuous and hazardous to human agents. The more the number of industries increases in developing countries and even developed countries, the higher the demands for laborers in carrying out several operations in these industries (Harish et al., 2019). Time and adequate manpower are major constraints in carrying out large-scale tasks in industries hence the need for machines or systems to save human efforts in the industries. The costs of maintaining human labour in the industries keep rising, the price of buying and maintaining robots is reducing (Ropo et al., 2018). While robots become more cost-effective at their jobs, human labour continues to be expensive and less productive, hence more industrial jobs are being taken over by robots.

An industrial robot is a re-programmable multifunctional manipulator designed to move material, parts, tools, or specialized devices through variable programmed motion for the performance of a variety of tasks - the definition from the Robot Institute of America to reflect main features of modern robot systems. An industrial robot system

can include any devices or sensors together with the industrial robots to perform its tasks as well as sequencing or monitoring communication interfaces. (Elfasakhany et al., 2011)

One of the vital functions of an industrial robot is the pick and place function. This operation includes lifting a payload from within its workspace, or carrying it to a predetermined location where the load is released. The picking and dropping of loads in industries seem to be one of the most highly repetitive processes with a high call for timeliness and accuracy. Human's efforts most times fall short of these demands hence the need for a smarter and more efficient system in handling this process. By simply introducing the autonomous robotics applications, simple repetitive tasks can be accomplished by keeping demands of accuracy and speed in mind which will result in optimal utilization of the machine and manpower. An essential goal in the development of robots is to have them interact with their surroundings. Typically, an arm and a grasping tool or end effectors are used to execute this interaction. A robot manipulator is programmed to perform similar functions to that of a human arm; the arm may be part of a more complex robot. The links of such a manipulator are connected by joints allowing either rotational motion or translational (linear) displacement and can be considered to form a kinematic chain, the terminus of which is called the end effector and it is analogous to the human hand (Kruthika et al., 2017).

II. MAIN COMPONENTS

To make the robotic arm the following parts/components are required (as shown in Table 1).

TABLE I
PARTS/COMPONENTS OF THE ROBOTIC ARM

Servo motor	Voltage regulator (7806)
Electro magnet	Transistor BC555
Wooden and metal links	Regulator: constant 5V
Pattress box	Bero-board
Relay (6V)	Switch
Arduino Uno	Pattress box
19v power supply	

Servo motor: Servo motors as seen in Figure 1 are electronic actuators devices that rotate pushing parts of a machine with precision. A servomotor is a motor, which forms part of a servomechanism often paired with some type of encoder to provide position/speed feedback.



Fig. 1 Servo motor

Electromagnet: Electromagnets as seen in figure 2 are made of coils of wire with electricity passing through them. Moving charges create magnetic fields, so when the coils of wire in an electromagnet have an electric current passing through them, the coils behave like a magnet. Electromagnets are used in a lot of electronic devices when magnetic forces are only needed for short periods of time. Electromagnetic gripper is a type of end effector mounted at the end of the robotic arm, that can catch and transfer steel parts or ferrous materials in automated assembly operations (Islam & Islam, 2014). Magnetic end effector, also known as magnetic grippers or robot magnetic end-of-arm tool, is a must-have for robotic pick and place of steel parts, especially in intelligent manufacturing

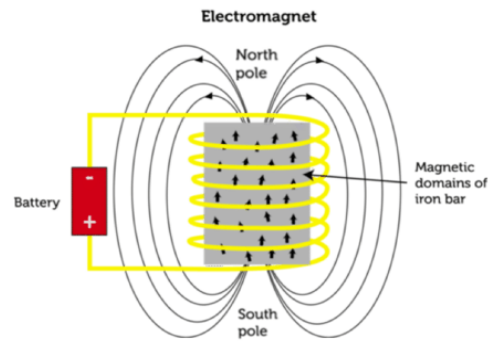

Fig. 2 Electromagnets (Islam & Islam, 2014)

Arduino Uno: Arduino Uno as seen in Figure 3 is a microcontroller board based on the ATmega328P (datasheet) having 14 digital input/output pins, 6 analogue inputs, a 16 MHz ceramic resonator (CSTCE16M0V53-R0), a USB connection, a power jack, an ICSP header and a reset button. It can simply be connected to a computer using a USB cable or powered with an AC-to-DC adapter or battery. Arduino uno is a low-cost, flexible, and easy-to-use programmable open-source microcontroller board that can be integrated into a variety of electronic projects (Jambotkar, 2017) which can also be interfaced with other Arduino boards, Arduino shields, Raspberry Pi boards and can control relays, LEDs, servos, and motors as an output.

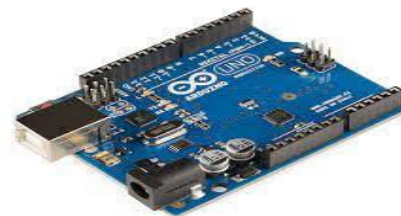

Fig. 3 Arduino uno ATmega328P (Jambotkar, 2017)

III. METHODOLOGY

This research work follows three stage which solves its objectives. This can be seen from the design block in Figure 4.

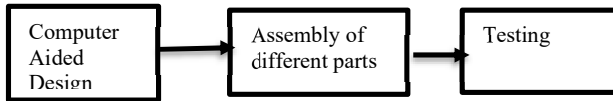

Fig. 4 Design block diagram

A. Computer Aided Design (CAD)

The first stage is the Computer Aided Design (CAD) design stage. In this stage, solid works 2018 software was used to design a 3D model of the system. The software was used to design the individual component that makes up the robotic arm as seen in figure 5 then assembly drawing was then used to bring together these parts. Figure 6 shows the 3D model of the whole system.

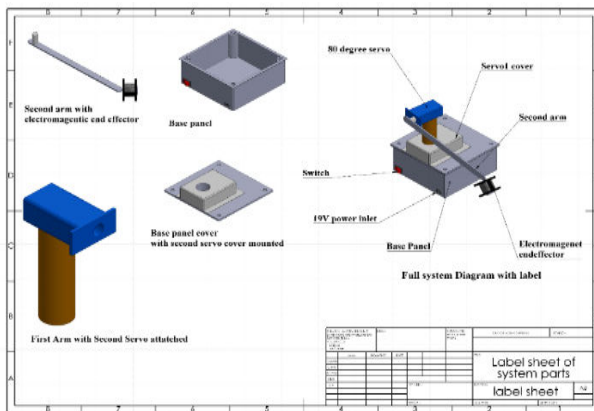

Fig. 5 System parts label

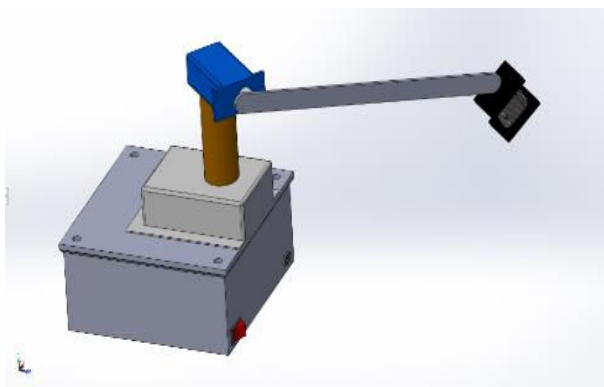

Fig. 6 System 3D model

B. Fabrication And Assembly

The robot arm was designed using a top-down technique; however, it was constructed piece by piece and then its individual components were assembled to form the entire arm.

For equilibrium, the actuators (two servo motors) are positioned in the centre of the upper base. The motors are controlled by a 5-volt power supply. By programming the microcontroller, the servo motor that is attached to the upper base is rotated 180 degrees. The second servo motor is also angled between 180 and 270 degrees. Three relays that operate on 5 volts are utilized to magnetize the gripper. The relays are magnetized and connected to one another so that they may grasp any metallic object. The model is powered by a battery that has a 5 volt and 1 ampere capacity as depicted in Figure 7.

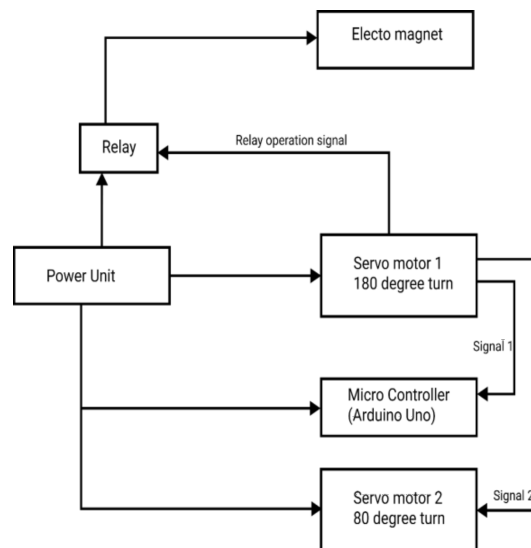

Fig. 7 System operation block diagram

The robotic arm functions just like a human hand. Because of the magnet, it has a strong grip. It can retain a light metal sheet in a moving position using the grasping. After some time, the magnet's power turns on, holding the sheet metal as it is moved from one location to another.

Two servo motors are employed in this situation to carry the sheet metal. One servo motor rotates horizontally, moving hand to the horizontal position, while another rotates vertically, moving the hand to the vertical position. Microcontrollers control the entire system. The microcontroller is pre-programmed to make a decision for any input and transmit that decision to the motors and magnetic grip as shown in Figure 8. The microcontroller generates the output for the magnetic grip when the hand is in the correct alignment. The motor in this case is swung by the BD555 Transistor. An LM7805 acts as a consistent power source in the circuit.

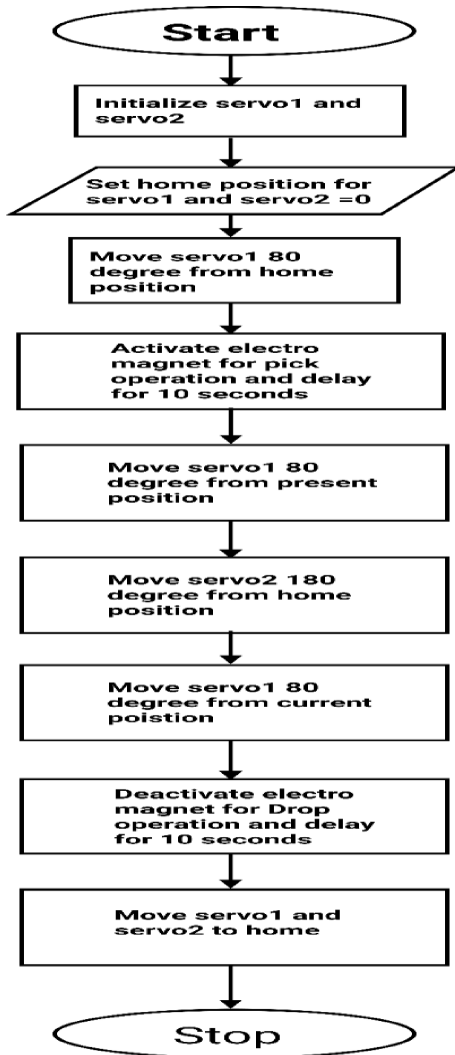

Fig. 8 Flow chat of the operation of the robotic arm

C. Testing

The testing phase, the solid works was used to obtain the graph for the angular displacement, velocity and acceleration via motion study feature. And the proteus was used to simulate the electrical circuit to see how it works. Figure 9 shows the proteus schematic circuit diagram.

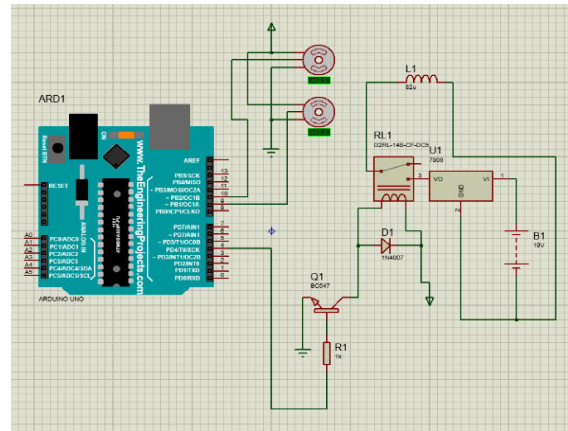

Fig. 9 Circuit diagram

Figures 10 and 11 shows the graph of the angular displacement of the system for link 1 and link 2 respectively. The angular displacement is plotted against the time it takes from the link to move from home position to the final position. The graph presented from Figure 12 and Figure 13 describes the angular velocity of the links 1 and 2 respectively as they transform from one position to the other with respect to time. The graph presented from Figure 14 and Figure 15 describes the angular acceleration of the links 1 and 2 respectively as they transform from one position to the other with respect to time.

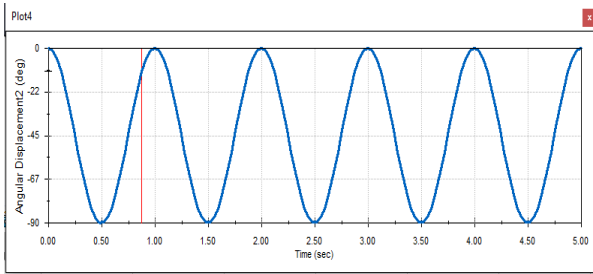

Fig. 10 The graph of the angular displacement of link 1

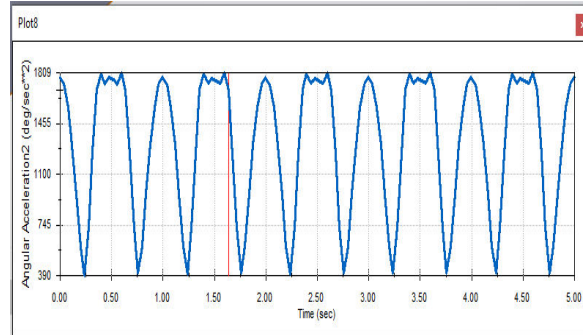

Fig. 14 The graph of the angular acceleration of link 1

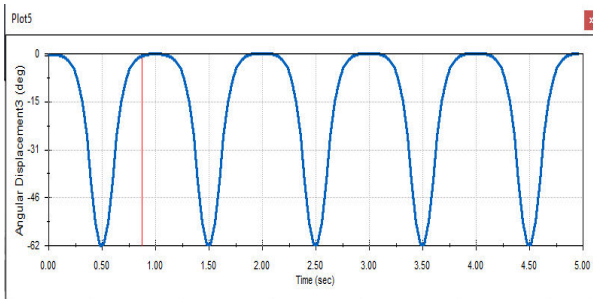

Fig. 11 The graph of the angular displacement of link 2

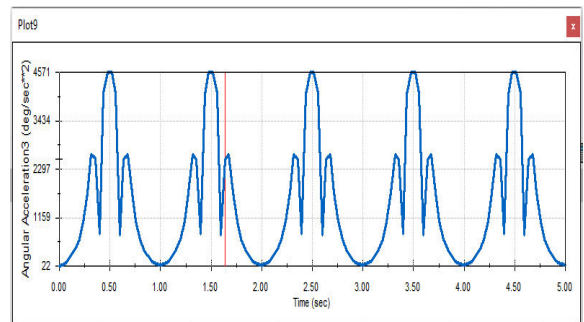

Fig. 15 The graph of the angular acceleration of link 2

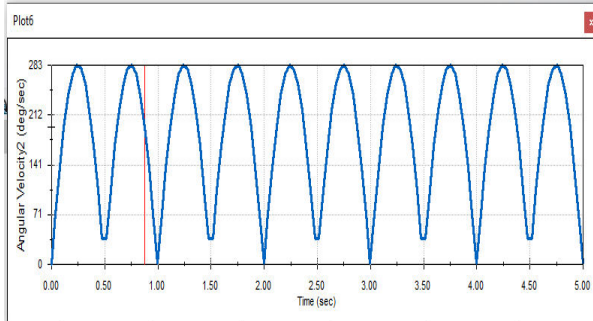

Fig. 12 The graph of the angular velocity of link 1

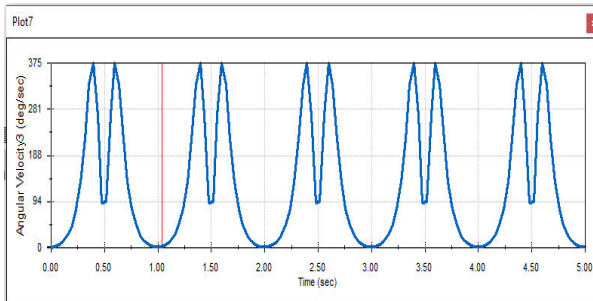

Fig. 13 The graph of the angular velocity of link 2

IV. DISCUSSION OF RESULT

The goal of this research work was to develop, and control a prototype robotic arm that loads and unloads light metal sheets using electromagnetic grippers.

The outcome demonstrates that servo motors 1 and 2 are at a 0-degree angle, which is the home position for the robotic arm. This is to ensure that the picking link is at a convenient workspace for it to pick the sheet metal. Then the electro magnet is then actuated by the relay connected to pin 4 of the Arduino. This allows 19 volts to flow to the electromagnet to pick the sheet metal. After this is completed by delaying the system for 10 seconds, then the servo 1 is then set to 0 degree again in other to put the arm in a safe workspace for the second servo to move to the drop position. Then the second servo is then move to 180 degrees (the drop position). The servo 1 is then moved again to 80 degree and the electromagnet is deactivated.

V. CONCLUSION

Robotic arms are perfect for tasks that need to be repeated, reliable, and of a very high calibre. The pick-and-drop process can be made more accurate, economical, and predictable by automating it. Using a robotic arm offers various benefits, including increased production capacity and manufacturing process precision. Assembling, packaging, bin selecting, and other tasks are some of the uses for pick and drop robots.

The goals are established based on these requirements, and the research activities (design, fabrication, installation, and controlling the robotic arm) have been successfully completed.

The robotic arm's mechanical and electrical architecture is fairly straightforward. By using a magnetic gripper, the robotic arm is capable of loading and unloading steel metal objects. The arm has a 180-degree vertical range of motion. The program of the microcontroller makes it simple to regulate the arm's speed and direction.

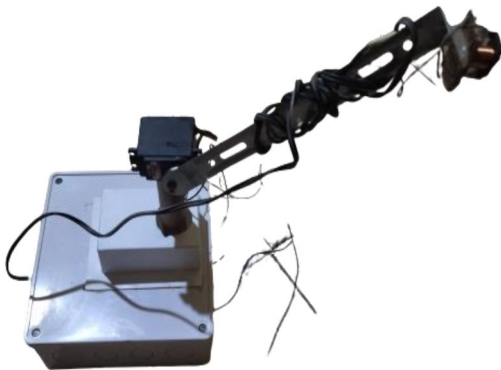

Fig. 16 Image of the final design.

ACKNOWLEDGMENT

We want to express our sincere thanks to the Almighty God. We also value the kind assistance and collaboration friends and colleagues for their inputs for the successful completion of this project. We also like to thank the workshop staff and students for their kind support in making this project a success and producing the required results.

REFERENCES

- Harish, K., Megha, D., Shuklambari, M., Amit, K., & Jambotkar, C. K. (2019). *Pick and Place Robotic Arm Using Arduino*. April.
- Islam, T., & Islam, M. R. (2014). *05-P-15: DESIGN & FABRICATION OF A ROBOTIC ARM MODEL WITH MAGNETIC GRIPPER ABIOTIC PHYSIOLOGY VIEW PROJECT INVESTIGATION AND PERFORMANCE ANALYSIS OF A SMALL SCALE SAVONIUS WATER CURRENT TURBINE IN PERSPECTIVE OF BANGLADESH* View project. <https://www.researchgate.net/publication/344844111>
- Jambotkar, C. K. (2017). *Pick and Place Robotic Arm Using Arduino*. International Journal of Science, Engineering and Tech. Research (*IJSETR*) (Vol. 6). <https://www.researchgate.net/publication/332565132>.
- Kruthika, K., Kiran Kumar, B. M., & Lakshminarayanan, S. (2017, September 27). Design and development of a robotic arm. *2016 International Conference on Circuits, Controls Communications and Computing, 14C 2016*. <https://doi.org/10.1109/CIMCA.2016.8053274>.
- Moe Myint, K., Min Min Htun, Z., & Myo Tun, H. (2016). Position Control Method For Pick And Place Robot Arm For obj. Sorting System. *INTERNATIONAL JOURNAL OF SCIENTIFIC & TECHNOLOGY RESEARCH*, 5(06). www.ijstr.org
- Ropo, O. O., Adekunle, O. F., Oluwaseun, O. A., & Babatope O. P. (2018). Design of a Pick and Place Serial Manipulator. *IOP Conference Series: Materials Science and Eng.* 413(1). <https://doi.org/10.1088/1757-899X/413/1/012056>
- Elfasakhany, A., Yanez, E., Baylon, K., & Salgado, R. (2011). Design and Development of a Competitive Low-Cost Robot Arm with Four Degrees of Freedom. *Modem Mechanical Eng.* 01(02), 47–55. <https://doi.org/10.4236/mme.2011.12007>